

# Mono-Amplifier 501

## User Manual



souldution  
nature of sound





**Dear Client**

We are proud that you decided yourself for a solution product. You have acquired a product with outstanding sonic performance which you will enjoy for many years.

We understand your eagerness to get started but even though please study this manual step by step before you integrate the Mono-Amplifier 501 in your High Fidelity system. This manual contains also useful tips for the optimisation of your overall HiFi-system.

If there are any questions regarding the start-up or operation of your mono-Amplifier 501 please do not hesitate to contact your dealer.

**Have fun!**



**Your solution Team**



## CE-Declaration of Conformity

Spemot AG declares that this product is in conformance with the following directives and standards:

Low Voltage Directive 2006/95/EG (EN/IEC 60065:2002)

Electromagnetic Compatibility 2004/108/EG (EN 55013:2001, EN 55020:2002, EN 61000-3-2:2006, EN61000-3-3:1995)

## FCC-Notice

Note: This equipment has been tested and found to comply with the limits for a Class B digital device, pursuant to Part 15 of the FCC Rules. These limits are designed to provide reasonable protection against harmful interference in a residential installation. This equipment generates, uses and can radiate radio frequency energy and, if not installed and used in accordance with the instructions, may cause harmful interference to radio communications. However there is no guarantee that interference will not occur in a particular installation.

If this equipment does cause harmful interference to radio or television reception, which can be determined by turning the equipment off and on, the user is encouraged to try to correct the interference by one or more of the following measures:

- adjust or relocate the receiving antenna
- increase the separation between the equipment and the receiver
- connect the equipment into a mains outlet on a circuit different from that to which the receiver is connected
- consult the dealer or an experienced radio/TV technician for help

## Disposal

According to the Directive 2002/96/EG of the European Parliament used consumer-electro technical appliances have to be disposed separately and have to be indicated with the following symbol.



In the case of disposal of this component please do so in conformity with legal and environmental regulations.







## Table of contents

1	Quick start.....	5
2	Important security advices: .....	6
3	Technical Highlights.....	8
3.1	Power amplifier .....	8
3.2	Power supply .....	8
4	Start of operation and handling of the Mono-Amplifier 501 .....	9
4.1	Scope of delivery and packing .....	9
4.2	Optimal positioning of your Mono-Amplifier 501 .....	9
4.3	Rear panel of the Mono-Amplifier 501 .....	10
4.4	Front panel of the Mono-Amplifier 501 .....	13
5	Protection functions of the Mono-Amplifier 501 .....	14
6	Trouble shooting .....	15
6.1	Actions after the appearance of an error .....	15
7	Care and maintenance .....	16
7.1	Burn-in.....	16
7.2	Cleaning .....	16
8	Service .....	17
9	Guarantee .....	17
10	Specifications .....	18
11	Dimensions.....	19





## 1 Quick start

<b>Unpacking</b>	<p>Unpack the Mono-Amplifier 501 and store the packing for future transportations.</p> <p> Your Mono-Amplifier 501 has a top class surface. Please take care during installation.</p>
<b>Positioning</b>	<p>Position the Mono-Amplifier 501 on a stable base.</p> <p> Cooling air must be able to circulate and escape unrestricted.</p>
<b>Cabling</b>	<p>Disconnect all electrical appliances of your HiFi-system from the mains supply. Connect your Mono-Amplifier 501 with your preamplifier (according to user manual) and your loudspeakers. Use the respective signal cables and the cable for the LINK-system. Reconnect the Mono-Amplifier 501 and all other components of your HiFi-system with the mains supply.</p> <p> While manipulating with cables the Mono-Amplifier 501 has to remain disconnected from the mains.</p>
<b>Switch on</b>	<p>Switch on your source device and your preamplifier. Turn down the volume of your preamplifier. Switch on your Mono-Amplifier 501.</p> <p> Check for correct cabling before switch-on of your Mono-Amplifier 501.</p>



## 2 Important security advices:

### User manual:

Read this user manual carefully before you start-up the Mono-Amplifier 501 and follow all installation and security advices.

Please keep this user manual.

### Mains supply:

Exclusively use 3 phase power cords with ground conductor. They may not be crushed by objects.

Unplug your Mono-Amplifier 501 from the mains connection in the following cases:

- before you manipulate with cables
- before cleaning
- during thunder storms or
- before you leave for longer periods

### Cabling:

While manipulating with cables the Mono-Amplifier 501 has to remain disconnected from the mains. Before you disconnect the mains the Mono-Amplifier 501 has to be in operating condition OFF. Wrong cabling may cause damages to your Mono-Amplifier 501, your (pre)amplifier or to your loudspeakers. Excessive volumes due to inappropriate handling may cause hearing damages.

### Transport:

Use only with the cart, stand, tripod, bracket or table specified by the manufacturer or sold with the apparatus. When a cart is used, use caution when moving cart/apparatus combination to avoid injury or tip over.





### **Packing:**

Please keep the original packing for future transports. The original packing is optimal protection against potential damages.

### **Operation:**

Never run your Mono-Amplifier 501

- with opened housing
- with closed cooling-slots
- with high ambient temperatures (>40°C)
- close to heat sources like radiators, heatings, ovens or similar appliances dissipating heat
- with extremely high humidity for example in humid cellars or rooms similar humidity
- close to water (Sink, bathtub, or similar equipment)

### **Cleaning:**

Use a soft and dry towel. We suggest using a non abrasive micro fibre towel. Please do not use any solvents or liquidities.

### **Service:**

Do not try to repair your Mono-Amplifier 501 by yourself. It needs a service check by a qualified person in the following cases:

- the mains-cable or the mains connectors are damaged
- foreign substances or liquidity has entered the Mono-Amplifier 501
- the Mono-Amplifier 501 has seen rain
- the Mono-Amplifier 501 seems to malfunction
- the Mono-Amplifier 501 has fallen to the floor or the housing is damaged

**Serial-Nr.:**      **501 -** \_\_\_\_\_

Please note the serial-number of your Mono-Amplifier 501 above.



### 3 Technical Highlights

#### 3.1 Power amplifier

The new power amplification circuit of the 501 is based on the technology used for amplifiers 700 and 710. This new voltage amplifier technology works without any feedback to the input (no differential amplification). It is built from linearised amplification units that run up to a frequency of 80 MHz.

The current amplification is done in three stages, each stage working in a narrow and nearly linear operating area. Its rather high class A operation mode combined with 47'000  $\mu$ F capacitance leads to nearly unlimited impulse reproduction. Massive copper rails on the circuit board as well as to the binding posts ensure that all the power is really conveyed to the loudspeaker.

A highly precise idle-current regulation ensures optimal class A operation for all conditions without the necessity of any post control in the music signal. Best sonic performance will be available immediately and independent of the operating temperature of the amplifier.

Comprehensive safety functions ensure safe operation. The 501 Mono-amplifier is protected against high frequency and DC signals at the inputs as well as against shortcuts in the output. Additionally the input level is permanently monitored.

#### 3.2 Power supply

6 power supply units – each optimized for its specific function – provide the required supply voltages. The power supply units supplying the control circuits of the 501 Mono-amplifier are perfectly decoupled from the power supply units of the amplifier section by galvanic isolation and opto-couplers.

Two switched mode power supply units with 1'200VA in combination with HighPerformance filters in the input and output of the power supply units provide supply voltages in audiophile quality. Locally they get further controlled by 6 soulution high speed voltage regulators and are by far more stable than any traditional, trafo-based, power supply technology possibly could provide.



## 4 Start of operation and handling of the Mono-Amplifier 501

Please take care while installing the Mono-Amplifier 501. Follow all safety advices!

### 4.1 Scope of delivery and packing

Please check the scope of delivery:

- Mono-Amplifier 501
- mains cable
- user manual

Store the packing of the Mono-Amplifier 501 for future transports. Check your mono-amplifier 501 for transport damages. In the case your Mono-Amplifier 501 is damaged please contact your solution dealer.



If your Mono-Amplifier 501 is still very cold from the transport, please let it warm within the packing, in order to omit condensation of water inside your Mono-Amplifier 501.

### 4.2 Optimal positioning of your Mono-Amplifier 501

There are no limitations on where to position your Mono-Amplifier 501. We suggest positioning the Mono-Amplifier 501 so that the connecting cables to the loudspeakers and the preamplifier remain short.



Please follow the safety advices on page 6!

The Mono-Amplifier 501 has a high quality surface. Please be careful while transporting so that the surface does not get scratched.



### 4.3 Rear panel of the Mono-Amplifier 501

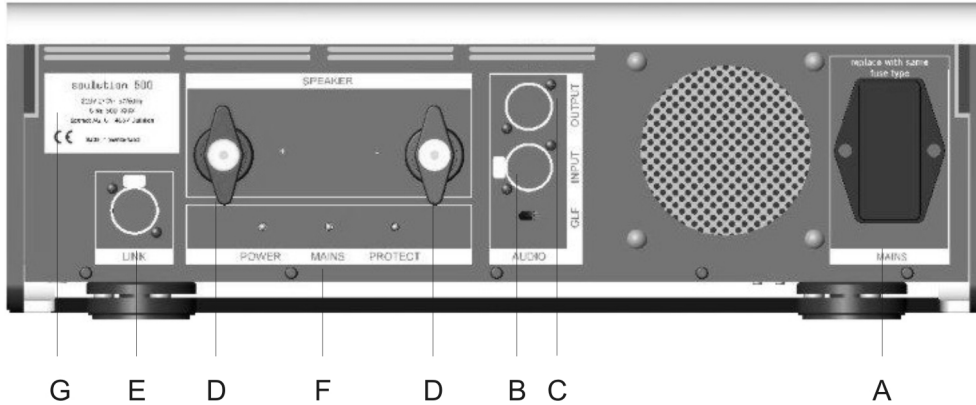

Rear Panel of Mono-Amplifier 501

#### 4.3.1 Mains (A)

Connect the Mono-Amplifier 501 with the mains supply. Amplifiers with high power ratings require high quality mains installation. Poor quality of the mains installation can reduce the sonic performances or even provoke malfunction.

After switch-on the power supplies the Mono-Amplifier 501 get started. As soon as constant conditions for the power supplies are reached the Mono-Amplifier 501 changes to operating condition OFF (Mains LED active, power consumption <0.5W).



Only switch-off the mains connection if your Mono-Amplifier 501 is in operating condition OFF.

#### 4.3.2 Balanced input (B)

Connect your Mono-Amplifier 501 with balanced interconnect cables to your pre-amplifier



Please follow the safety advices on page 6!



### 4.3.3 Balanced output (C)

The Mono-Amplifier 501 has as well a balanced output for the connection of additional amplifiers (bi-amplification).



Please follow the safety advices on page 6!

### 4.3.4 Speaker (D)

Connect your loudspeakers to the amplifier. The tremendous stability of the Mono-Amplifier 501 ensures optimal operation for all types of speaker cables. Never the less we recommend using top quality speaker cables.



Please follow the safety advices on page 6!

While manipulating with cables the Mono-Amplifier 501 has to remain disconnected from the mains.

Check the connectors for tight fit and for eventual damages. Short circuits provoked by thin threads from loudspeaker cables may cause fire.

### 4.3.5 LINK (E)

With the LINK-system the Mono-Amplifier 501 can be remote controlled. Connect the LINK-IN of your Mono-Amplifier 501 with the LINK-OUT of your preamplifier 720/721/520 or the Digital Player 540. With LINK-OUT you may connect further components to the LINK-network.



#### 4.3.6 Operating condition (F)

Three LEDs at the rear panel show the operating condition of the Mono-Amplifier 501.

**MAINS**            MAINS LED is active and indicates correct operation of the standby power supply. In case the LED is not active after switch-on of the mains switch please check the fuse in the mains filter.

**POWER:**        The main power supplies get started. If no malfunction is detected the POWER LED is activated.

**PROTECT:**      Operating condition PROTECT indicates that there is a malfunction detected and the mono amplifier 501 is not ready for operation. Please follow the instruction on page 15.

#### 4.3.7 Type label (G)

Please note the serial number of your Mono-Amplifier 501 on page 7 of this user manual. This allows you to have the product specific data at hand without removing your mono-amplifier from the HiFi rack.



## 4.4 Front panel of the Mono-Amplifier 501

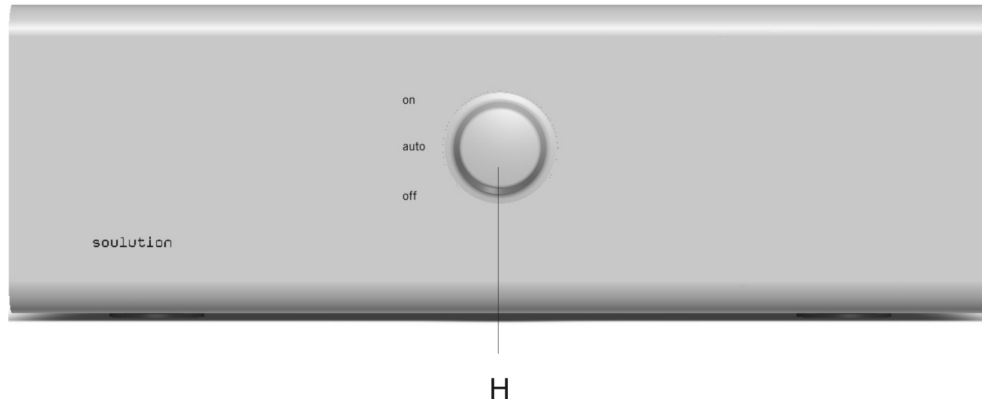

Front panel of the Mono-Amplifier 501

### 4.4.1 Rotary switch (H)

The operating condition (OFF, ON, AUTO) is selected by the rotary switch.

OFF: the Mono-Amplifier 501 is in standby

ON: the Mono-Amplifier 501 is ready for operation

AUTO: the Mono-Amplifier 501 follows the LINK signal

While not listening to music we suggest switching OFF your Mono-Amplifier 501 (power consumption <0.5W).



Please follow the safety advices on page 6!



## 5 Protection functions of the Mono-Amplifier 501

Comprehensive protection functions ensure safe operation and a long lifetime

### **Overcurrent:**

If the output current to the loudspeakers exceeds 45A the Mono-Amplifier 501 is switched off automatically.

### **Fuse**

The main fuse is located within the mains switch on the rear side of the Mono-Amplifier 501. Please replace with the same fuse type.

Model 100-120 V, 50-60Hz

16A/T 250V micro fuse 5x20mm

Model 220-240 V, 50-60Hz

10A/T 250V micro fuse 5x20mm





## 6 Trouble shooting

Error	Measure
<b>No music</b>	<p>Please check</p> <ul style="list-style-type: none"> <li>- The cabling to the mains</li> <li>- The main fuse of the Mono-Amplifier 501</li> <li>- Your mains installation</li> <li>- If the Mono-Amplifier 501 is switched on</li> <li>- The cabling to the preamplifier and the loudspeakers</li> <li>- If your source or preamplifier is switched to MUTE</li> <li>- The LINK-connection</li> </ul>
<b>PROTECT</b>	<p>In case a protection function has been activated, the Mono-Amplifier 501 changes to PROTECT mode. (LED at the rear panel)</p> <ul style="list-style-type: none"> <li>- Disconnect the Mono-Amplifier 501 from the mains. Reconnect it and try to switch-on again.</li> <li>- If the PROTECT mode remains active, contact your dealer.</li> </ul>

### 6.1 Actions after the appearance of an error

If you can not identify the error please disconnect the mains and contact your solution dealer.



## 7 Care and maintenance

### 7.1 Burn-in

The Mono-Amplifier 501 will play on top level immediately after the first placing into operation. However during the first 20-50 hours of operation you will notice a further improvement of its sonic qualities.

### 7.2 Cleaning

Please use a soft towel for the cleaning of your Mono-Amplifier 501. We recommend the use of a nonabrasive micro fibre towel. Please do not employ any solvents.



Liquidity is not allowed to enter the Mono-Amplifier 501. The electronic may be damaged seriously.



## 8 Service

If the Mono-Amplifier 501 needs service please contact your solution dealer.

## 9 Guarantee

All solution products are guaranteed against defects in material and workmanship for five years from date of purchase.

The guarantee is void if the Mono-Amplifier 501 has been subject to misuse, or negligence or has been modified, repaired or opened by a non authorised person without written authorisation of Spemot AG.

For the return transport to our premises please use exclusively the original packaging. Transport damages are not subject to this guarantee, repairs will be charged. We recommend effecting a transport insurance.

If you do not possess the original packaging no more please contact your solution dealer.

Basic repairs may be completed by your solution dealer. Please clarify whether he is able to do the work before you send the Mono-Amplifier 501 back to us.



## 10 Specifications

Specification	Data
<b>General</b>	
Nominal voltage	Model 100 - 120V Model 220 - 240V
Nominal consumption	1'400 W
Standby	<0.5 W
<b>Input</b>	
Impedance	2 k $\Omega$
<b>Main-Out</b>	
Power rating	@ 8 $\Omega$ 125 W @ 4 $\Omega$ 250 W @ 2 $\Omega$ (dynamic) 500 W
Output current	45 A max
Amplification	+26 dB
Frequency response	DC-800 kHz
Slew rate	0.9 $\mu$ s
Distortion (THD+N)	<0.001 %
Damping factor	>10'000
Signal-to-Noise ratio	>120 dB
<b>LINK-System</b>	
LINK-IN	+12 V
<b>Dimensions</b>	
Width x Depth x Height	442x448x143 mm
Weight	ca. 22 kg

Technical specifications are subject to change without prior notification.



11 Dimensions

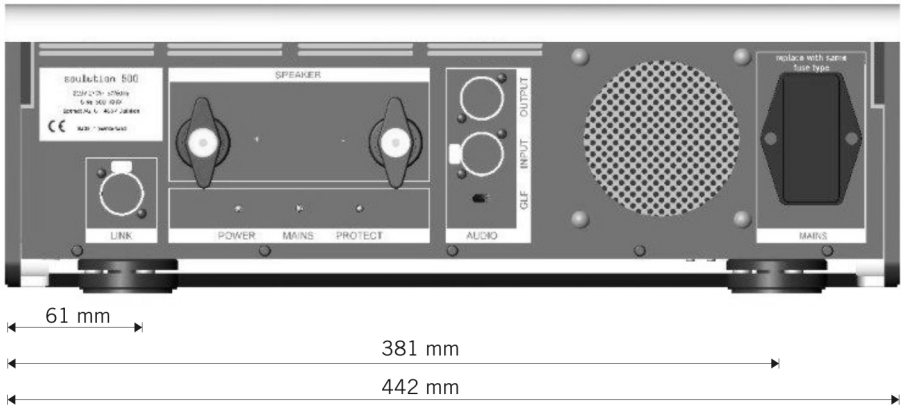
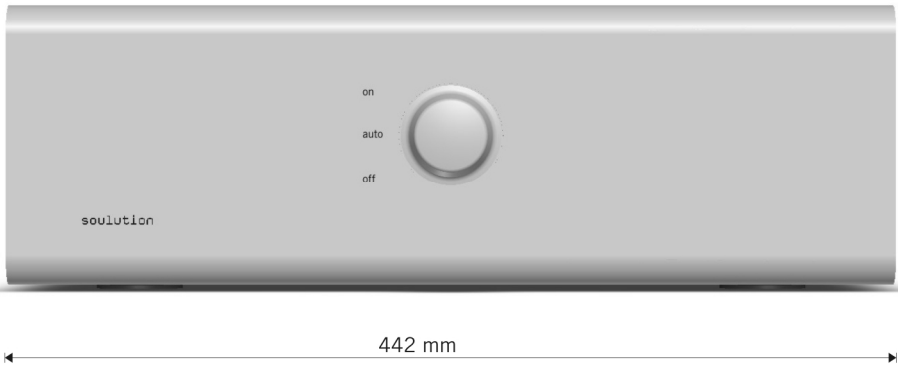
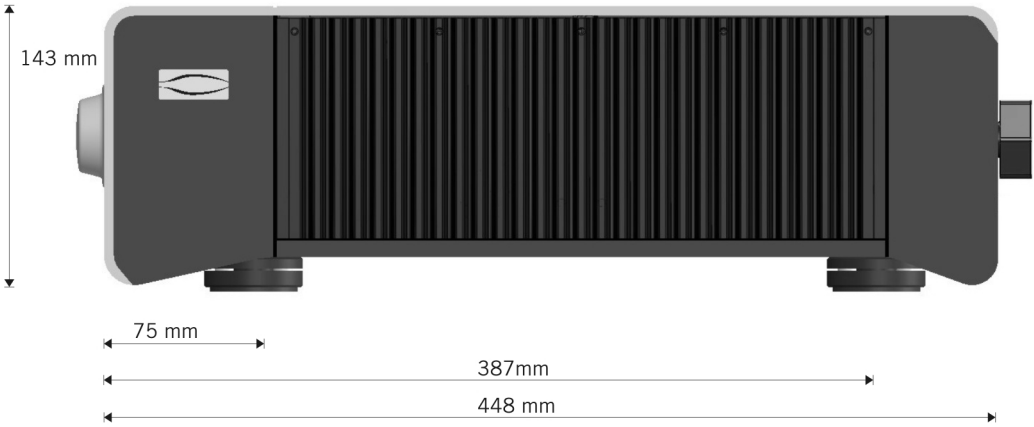



Spemot AG  
Industriestrasse 70  
CH-4657 Dulliken

[www.soulution-audio.com](http://www.soulution-audio.com)  
[info@soulution-audio.com](mailto:info@soulution-audio.com)



part.no. 92145